



Research paper / Praca doświadczalna

Change of dynamic characteristics of foamed explosive substances under the influence of ultrasonic radiation Zmiana charakterystyki dynamicznej spienionych materiałów wybuchowych pod wpływem promieniowania ultradźwiękowego

Viktor Boiko¹⁾, Viktor Kravets²⁾, Anatolii Han²⁾, Olena Han²⁾, Roman Zakusylo^{3,*)}

¹⁾ *Research Laboratory for Problems of Seismic Safety of Technological Explosions, Institute of Hydromechanics of the National Academy of Sciences of Ukraine, Kyiv, Ukraine*

²⁾ *Department of Geoengineering, National Technical University of Ukraine «Igor Sikorsky Kyiv Polytechnic Institute», Kyiv, Ukraine*

³⁾ *Shostka Institute of Sumy State University, Shostka, Ukraine*

*E-mail: r.zakusylo@ishostka.sumdu.edu.ua

Abstract: *Compositions of low-density foamed explosives based on ammonium nitrate (AN), surfactants and aluminum powder were obtained. The dynamic and physico-chemical characteristics of the foamed substances were determined and the influence of ultrasonic radiation on them researched.*

The dependence of the physical stability of foamed explosives on the effect of ultrasonics on AN was obtained and it was found that the greatest physical stability was achieved when treating AN with ultrasonic radiation for 4 min.

The scheme of the device and the method of preparation of such low-density foamed explosives are described. The use of low-speed mechanical mixing of the surfactant solution and treatment with ultrasonic radiation and crushed AN with the addition of 3-4% of dispersed aluminum resulted in materials, which, after appropriate aeration, can be fed directly to the blasting site.

Streszczenie: *Otrzymano kompozycję spienionych materiałów wybuchowych o małej gęstości, na bazie azotanu amonu (AA), roztworu środków powierzchniowo-czynnych i proszku aluminiowego. Określono właściwości dynamiczne i fizykochemiczne proponowanych kompozycji spienionych oraz zbadano wpływ na nie promieniowania ultradźwiękowego.*

Uzyskano zależność trwałości fizycznej spienionych materiałów wybuchowych od oddziaływania bodźca ultradźwiękowego i stwierdzono, że największą stabilność fizyczną uzyskuje się przy oddziaływaniu ultradźwięków na AA przez 4 min.

Przedstawiono schemat urządzenia i sposób przygotowania takich spienionych materiałów wybuchowych o małej gęstości. Za pomocą wolnoobrotowego mechanicznego mieszania roztworu środka powierzchniowo-czynnego poddanego działaniu ultradźwięków i rozdrobnionego AA z dodatkiem 3-4% zdyspergowanego aluminium. Uzyskane materiały, o odpowiednim napowietrzeniu, mogą być stosowane bezpośrednio na miejscu prowadzenia robót strzałowych.

Keywords: foamed explosive composition, ammonium nitrate, aluminum powder, surfactants, device for ultrasonic radiation

Słowa kluczowe: spieniona kompozycja wybuchowa, azotan amonu, proszek aluminiowy, środek powierzchniowo-czynny, urządzenie do oddziaływania ultradźwiękowego

1. Introduction

Compaction of sagging unstable soils is the main technological process, and solving this problem and finding optimized solutions play a significant role in the construction industry and military matters. One of the promising areas of compaction of subsiding unstable soils is the development of new effective methods of compaction using explosive energy. Simple blasting technology provides wide application of this method in construction with further improvements in the parameters of explosives.

In [1], advanced low-density explosive mixtures for compaction of subsidence soils were proposed. However, the explosive method of compaction of soils proposed by the authors requires appropriate mechanization for the preparation of foamed explosive compositions and filling the required compaction area under pressure with this suspension. In addition, an important factor is to ensure the physical stability of explosives of this class, especially when compacting a large area, as well as ensuring adequate productivity and safety in the manufacture of large volumes of the finished product for large charges.

Improvements in explosive technology [2] should be aimed at ensuring the physical stability and dynamic characteristics of foamed explosive compositions. This is necessary for the effective use of explosives in the compaction of subsidence loamy soils and demining of minefields and to create security for the blasting itself. The study of the effect of ultrasonic radiation and dispersed additives on foamed explosive compositions is the actual problem.

In previous studies, a device for preparing a water-filled foam explosive composition was proposed and the component composition of the foamed explosives was selected. The main advantage of this method is the creation of safe working conditions. This is done by mechanical mixing at low speed without pre-foaming, a mixture of a solution of surfactants and ammonium nitrate (AN). Next, the suspension is fed under pressure and dosed aeration to the flow of the mixture, to the place of blasting. Direct delivery of the already foamed explosive composition to the place of application and the possibility of providing significant volumes of the finished product for large charges are due to the mobility of this device [3-5].

A selection of the composition of foamed explosives of local preparation is offered. It is based on powdered and liquid surfactants, allowing one to control the parameters of the explosive pulse, through the use of explosives of adjustable density. These conditions provide their possible use for uniform compaction of subsidence loamy soils to the required extent.

The main disadvantage of the proposed foam materials is the low physical stability of the composite, especially in the open charge, which is 9-24 h at a temperature range of +30 to -10 °C, and when the temperature drops to -15 °C, this stability drops sharply, which leads to the breakdown of the foam. At the same time the structure of the system is destroyed, gas inclusions are enlarged, which causes a decrease in the sensitivity of the system to the blast pulse. This is due to the fact that the preparation of the composite is carried out by introducing the foaming agent into the granular, rather than crushed AN, which reduces the detonation sensitivity and reduces the holding capacity of the manufactured water-filled foam explosive compositions.

It would also be advisable to use in the composition foamed additives of explosives in the form of a dispersed component, such as aluminum, thereby achieving penetration of the liquid phase into the microcracks of AN due to the lack of the wedge effect, which can also increase the physical stability of the foam. One of the main parameters which characterises the physical stability of water-filled foam explosive compositions based on AN, surfactants and water is the holding capacity of AN. In [6] it was found that the treatment of AN with ultrasound can significantly increase its holding capacity. At the same time, these results are nonlinear. That is, at the first stage, an increase in time of processing by ultrasound to 4 min, increases the holding

capacity of the AN to a maximum. A further increase in the sonication time of the speaker leads to a decrease in its holding capacity. This pattern is observed for both porous and dense AN. In addition, a significant effect to ensure the holding capacity [6] and the sensitivity of the system to the blast impulse can be achieved by the pre-treatment of AN with ultrasonic radiation [7, 8]. To control the parameters of the foamed explosive compositions, it is important to ensure the physical stability of the system itself, especially in open charges.

The purpose of the work is to ensure the physical stability of the foamed composition due to dispersed additives and ultrasonic treatment.

2. Experimental part

2.1. Materials

The component composition and characteristics of foamed pasty explosives are given in Tables 1 and 2. As can be seen from the data below, the density of explosive compositions due to the aeration of the mixture is regulated from 200 to 800 kg/m³, the critical diameter of the explosive charges in the hard shell is $(30-40) \cdot 10^{-3}$ m. Explosive charges in the hard shell are sensitive to a ED-8 detonator.

The physical stability of the aerated system in the temperature range +30 to -10 °C in an open vessel for foamed compositions without treatment of AN with ultrasonic radiation is 9-24 h, and after ultrasonic radiation of AN for 4 min it is within 11-28 h. A similar increase in physical stability is observed in a closed container. In addition, the physical stability of the foamed compositions is significantly affected by the aluminum additive, which increases the physical stability of the foamed compositions

Table 1. Component composition of foamed pasty explosives

No.	Component explosives	Compound [wt.%]				
		1	2	3	4	5
1	AN	92.0-93.3	89.8-92.9	86.5-88.5	90.5-91.5	83.5-84.5
2	Sulfosalts – black contact neutralized, refined	2.0-4.0	2.0-4.0	–	–	–
3	Refined alkylarylsulfonate	1.5-3.5	–	5.0-7.0	5.0-7.0	5.0-7.0
4	Ethylenediamine	0.2-0.5	–	–	–	–
5	Sodium alkyl sulfates	–	1.0-3.0	–	–	–
6	Contact Petrov	–	–	1.0-3.0	–	1.0-3.0
7	Carboxymethylcellulose	–	–	0.5-1.5	–	0.5-1.5
8	Sodium alkyl sulfates (secondary)	–	–	–	1.0-3.0	–
9	Polyacrylamide	–	–	–	0.5-1.5	–
10	Water	1.0-2.0	2.0-5.0	3.0-4.0	–	3.0-4.0
11	Aluminum powder	–	–	–	–	3.0-4.0

Table 2. Quantitative characteristics of foamed pasty explosives

No.	Parameter	Compound				
		1	2	3	4	5
1	Density [kg/m ³]	500-800	500-800	200-350	200-250	300-650
2	Multiplicity of foam	1.8-3.0	1.8-3.0	3.6-4.0	3.6-4.2	3.6-4.0
3	Critical diameter:					
	– open charge 10 ⁻³ [m]	50-70	50-80	50-70	60-90	50-70
	– in a hard shell 10 ⁻³ [m]	30-40				
4	Physical stability in the temperature range from +30 to –10 °C:					
	– in an open vessel [h]	9-10	10-12	14-17	20-24	15-18
	– in a closed vessel [day]	5-7	6-7	5-8	–	6-8
5	Physical stability in the temperature range from +30 to –10 °C after sonication with ultrasound (4 min):					
	– in an open vessel [h]	11-14	11-15	16-20	23-28	18-24
	– in a closed vessel [day]	6-8	7-9	6-10	–	7-11
6	Heat of explosion, 10 ³ [J/kg]	3500-3770	3520-3780	3500-3700	3500-3700	3530-3750
7	Minimum initiating impulse:					
	– open charge [kg TNT]	0.01-0.03	0.01-0.03	0.01-0.03	0.01-0.02	0.01-0.03
	– in a hard shell	ED-8				
8	Ice resistance	not ice resistant				

2.2. Device for ultrasonic radiation

For the preparation of such foamed explosive compositions proposed a device (Figure 1), which includes: a hopper (1) and a crusher for grinding granular AN (2), a surfactant container (3), a water container (4), a container with aluminum powder (5), a container of aqueous surfactant solution (6), low-speed mechanical mixer (7), storage tank (8), pump (9), nozzle (10), ejector (11), air metering valve (12), the barrel of the foam explosive mixture (13).

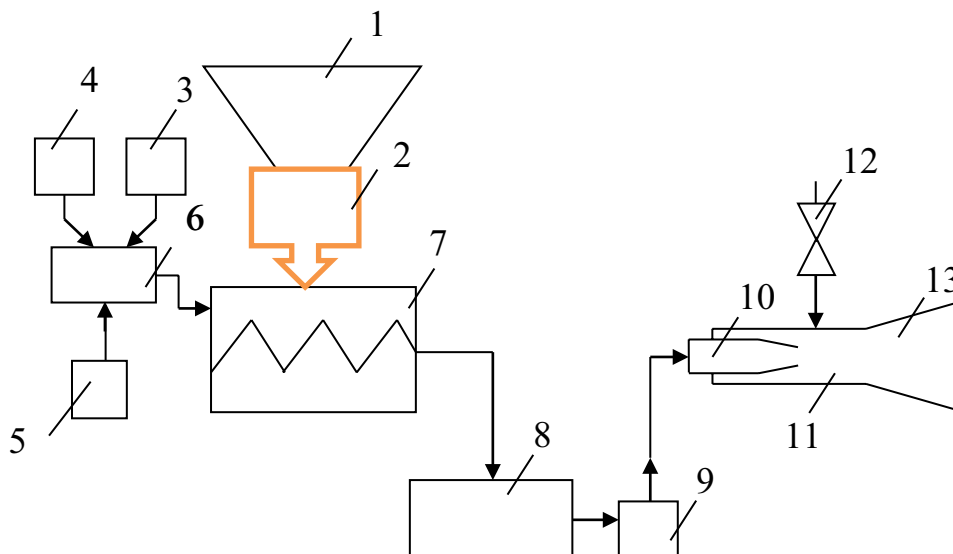
**Figure 1.** Schematic view of a device for preparing a water-filled foam explosive composition

The device works as follows. Granular pre-sonicated AN from the hopper (1) and the crusher (2) enters the mixer (7), which dispenses the surfactant solution from the container (6) and aluminum powder from the container (5). The finished suspension enters the storage container (8). Pumped (9) suspension is supplied under pressure to the nozzle (10). The high-speed flow of the suspension enters the ejector (11) and sucks the air coming from the atmosphere through the valve-dispenser (12). The flow is aerated, saturated with highly dispersed air bubbles. The resulting foam suspension enters the foam barrel (13) and already, as a foamed explosive composition, is fed directly to the place of blasting.

Due to the pre-treatment of AN with ultrasonic radiation and the addition of 3-4% of dispersed aluminum, it is possible to achieve significant physical stability and improve the dynamic characteristics of the proposed foamed explosive compositions. By means of the proposed device, considerable safety of directly carrying out explosive works is provided since an un-foamed mixture of surfactant solution and AN is not sensitive to shock and friction, and the explosive properties of this suspension are manifested only after saturation of the mixture with air bubbles at the outlet of the foam suspension from the ejector. The ejector direct-flow method significant volumes of foamed explosive composite allows to be produced.

3. Results and discussion

The dynamic characteristics of the foamed mixtures were studied both with the treatment of AN by ultrasonic radiation and without it. The dynamic characteristics of the foamed explosives are given in Table 3. From the below data it is seen that the rate of detonation of open charges of explosives without treatment of AN with ultrasonic radiation is $(1.0-2.5) \cdot 10^3$ m/s, and after treatment is $(1.2-2.6) \cdot 10^3$ m/s. The high explosiveness of the foamed mixtures is in the range of $(7-11) \cdot 10^{-3}$ m.

Table 3. Dynamic characteristics of foamed explosives

No.	Parameter	Unit	Compound				
			1	2	3	4	5
Without treatment of AN with ultrasonic radiation							
1	Detonation velocity:						
	– open charge	10^3 [m/s]	1.0-2.4	1.0-2.5	–	–	1.0-2.2
– charge in the hard shell	1.1-3.2		1.1-3.0	1.9-2.1	2.0-2.2	2.1-2.3	
2	Brisance in a steel ring	10^{-3} [m]	7-11	7-11	7-9	7-8	8-11
3	The time of increase of pressure in the pulse	10^{-6} [s]	40-50	45-50	50-55	50-60	55-60
4	Pressure at the wave front	10^9 [Pa]	0.7-0.8	0.7-0.8	0.6-0.7	0.5-0.7	0.6-0.8
5	Pressure rise rate	10^{14} [Pa/s]	0.14-0.20	0.14-0.17	0.11-0.14	0.08-0.14	0.12-0.16
After ultrasonic radiation of AN for 4 min							
1	Detonation velocity:						
	– open charge	10^3 [m/s]	1.2-2.4	1.3-2.6	–	–	1.2-2.3
– charge in the hard shell	1.3-3.3		1.2-3.1	1.9-2.2	2.0-2.3	2.2-2.4	
2	Brisance in a steel ring	10^{-3} [m]	7-11	7-11	7-9	7-8	8-11
3	The time of increase of pressure in the pulse	10^{-6} [s]	45-50	45-55	50-55	55-65	55-65
4	Pressure at the wave front	10^9 [Pa]	0.75-0.85	0.75-0.9	0.65-0.75	0.65-0.7	0.75-0.8
5	Pressure rise rate	10^{14} [Pa/s]	0.16-0.21	0.15-0.17	0.12-0.15	0.09-0.15	0.13-0.17

Analysis of these data shows that pre-treatment of AN with ultrasonic radiation significantly improves the dynamic characteristics of the proposed foamed explosives. A method of preparation of such foamed explosive compositions, including mechanical mixing of surfactant solution, AN, the granules of which are pre-sonicated and crushed in a crusher with the addition of 3-4% dispersed aluminum, which is carried out

at low speed without foaming the mixture to the object of blasting and dosed aeration due to the injection of air by the flow of the mixture with the direct delivery of the foamed explosive composition to the place of application.

4. Conclusions

- ◆ The device and method of preparation of foamed explosive compositions with supply to the place of use are proposed. The influence of ultrasonic radiation on the proposed foamed explosive compositions of local preparation on the basis of liquid surfactants is established.
- ◆ An increase in the physical stability of foamed explosive compositions in the temperature range of +30 to -10 °C was obtained by treating AN with ultrasonic radiation for 4 min, which is 2-4 h in an open container and 1-3 days in a closed container. Aluminum additive increases the physical stability of the foamed compositions from 14-17 up to 15-18 h and from 5-8 to 6-8 days, respectively, for aerated systems in open and closed containers without influence of AN with ultrasonic radiation and from 16-20 up to 18-24 h and from 6-10 to 7-11 days, respectively, for aerated systems in open and closed containers after influence of AN with ultrasonic radiation for 4 min.
- ◆ The dynamic characteristics of foamed mixtures with both the treatment of AN by ultrasonic radiation and without the influence of AN by ultrasonic radiation have been studied. It is established that the detonation velocity of open explosive charges without the influence of AN with ultrasonic radiation is $(1.0-2.5) \cdot 10^3$ m/s, and after influence $(1.2-2.6) \cdot 10^3$ m/s. The brisance of the foamed mixtures is in the range of $(7-11) \cdot 10^{-3}$ m for both explosives after the influence of AN with ultrasonic radiation and without the influence of AN with ultrasonic radiation.
- ◆ The time of increase of the pressure in the pulse to the maximum in the studied mixtures is close and is, respectively $(40-60) \cdot 10^{-6}$ s for charges without the influence of AN with ultrasonic radiation and $(45-65) \cdot 10^{-6}$ s for charges after the influence of AN with ultrasonic radiation. The pressure at the wave front in foamed explosives after treatment of AN with ultrasonic radiation is $(0.05-0.1) \cdot 10^9$ Pa higher than in foamed explosives without the influence of AN with ultrasonic radiation.
- ◆ The rate of increase of pressure in the pulse in foamed explosives after being influenced by AN with ultrasonic radiation is $(0.09-0.21) \cdot 10^{14}$ Pa/s, in foamed explosives without the influence of AN by ultrasonic radiation is $(0.08-0.20) \cdot 10^{14}$ Pa/s.
- ◆ It is established that the effect on AN by ultrasonic radiation significantly improves the dynamic characteristics of the proposed foamed explosives. The obtained dynamic characteristics indicate that the explosive compositions of this class can be used effectively in the compaction of subsidence loamy soils and the demining of minefields.

References

- [1] Boiko V., Han A., Han O. Surfacing Sunflowers by Improved Charges of Small Density. (in Ukrainian) *Collection of Research Papers of the National Mining University* **2018**, 55: 152-162.
- [2] Shakeran M., Eslami A., Ahmadpour M. Geotechnical Aspects of Explosive Compaction. *Shock Vib.* **2016**, 2, paper 6719271: 1-14.
- [3] Boiko V., Prykhodko Yu., Honchar V., Zolotukhin K., Orlov Yu., Pluzhnyk V., Han O. *Device for Preparation of Water-filled Explosive Composition*. (in Ukrainian) Utility Model Patent UA 122425, **2018**.
- [4] Kuprin V., Kuprin O., Ishchenko M., Savchenko M., Kovalenko I. *Method of Manufacturing Granular Explosive Mixtures for Pneumatic Charging from Ammonium Nitrate and Liquid Fuel*. (in Ukrainian) Utility Model Patent UA 106118, **2016**.
- [5] Zakusylo R. Investigation of Low-speed Nitroammonium Explosives of Increased Water Resistance. *Conf. Proc. Blasting Techniques 2018*, Banska Bystrica, Slovakia, **2018**, 297-302.

- [6] Yhnateva S., Bazotov V., Madiakyn V. Study of the Holding Capacity of Ammonium Nitrate in Diesel Fuel. *Bull. Univ. Technol.* **2016**, 5: 52-55.
- [7] Vasylchuk O.S., Vapnichna V.V., Han A.L. Influence of Ultrasonic Irradiation on the Holding Capacity of Ammonium Nitrate. (in Ukrainian) *Bull. Zhytomyr State Technol. Univ. Ser.: Tech. Sci.* **2018**, 1(81): 217-222.
- [8] Han O., Boiko V., Han A., Kravets V., Vapnichna V. Changes in Porosity and Holding Capacity of Ammonium Nitrate under the Influence of Ultrasonic Irradiation. (in Ukrainian) *Proc. 2nd Int. Sci. Tech. Conf. Problems of Geoengineering and Underground Urbanism*, Kiev, Ukraine, **2019**.

Received: May 31, 2021

Revised: October 20, 2021

First published online: October 29, 2021